

INSTRUCTIONS FOR YSI MODEL 53 BIOLOGICAL OXYGEN MONITOR

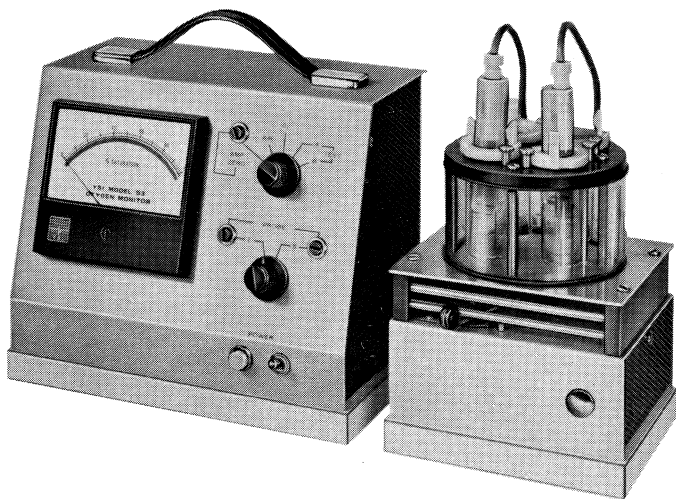

Scientific Division
Yellow Springs Instrument Co., Inc.
Yellow Springs, Ohio 45387, U.S.A. • Phone 513-767-7241



INSTRUCTION BOOK

YSI MODEL 53 BIOLOGICAL OXYGEN MONITOR

TABLE OF CONTENTS

230 VOLT INFORMATION	2
DESCRIPTION	3
SYSTEM SPECIFICATIONS	3
ASSEMBLING THE APPARATUS	4
MAKING A MEASUREMENT	5
DISCUSSION	
I — POLAROGRAPHIC OXYGEN SENSOR	6
II — 5301 STANDARD BATH ASSEMBLY	9
III — CALIBRATION	10
IV — ELECTRONIC UNIT	12
DETAILS OF OPERATION	
I — PROBE PREPARATION	12
II — SAMPLE CHAMBER AND BATH-STIRRER UNIT	14
MAINTENANCE	15
REPLACEMENT PARTS	16
WARRANTY	16
PROBE, PLUNGER AND SAMPLE CHAMBER DIAGRAM	17
SCHEMATIC	Inside Spread

230 VOLT INFORMATION

If this instrument has been purchased as a 230 VAC Model, the following notes should apply to statements made in the instructions.

Power Requirements:

1. 230 VAC — Operable from 190-250 VAC.
2. Wattage as stated in instructions.
3. Current requirement of instrument is one-half that stated.
4. Stirrer speed: 480 RPM @ 50 Hz — 576 RPM @ 60 Hz.
5. The schematic contains notes indicating changes which have been made to the circuit.

MODEL 53 BIOLOGICAL OXYGEN MONITOR

DESCRIPTION

The YSI Model 53 Biological Oxygen Monitor is a device for measuring oxygen uptake or evolution by biological systems. The instrument produces "Warburg" type oxygen evolution or uptake curves in 5 to 20 minutes.

The heart of the system is the YSI 5331 Oxygen Probe. This probe is a specially designed Clark type polarographic electrode.

The total system consists of the Model 53 Electronic Unit, the Model 5301 Standard Bath Assembly, two 5331 Oxygen Probes, one 5775 Probe Service Kit, and the 5350 Membrane Applicator Kit. A Constant Temperature Circulator supplied by the customer is also required.

SYSTEM SPECIFICATIONS

Ranges:	Full scale for air saturated solution @ 760 mm. Full scale for oxygen saturated solution @ 760 mm. Rate of oxygen consumption: 7-300 $\mu\text{l O}_2/\text{hr.}$ air saturated solution 35-1500 $\mu\text{l O}_2/\text{hr.}$ O_2 saturated solution
Sensor Linearity:	Within 1% of full scale.
Drift:	2% of full scale per hour max.
Stabilizing Time:	60 seconds maximum with probe and solution at operating temperature.
Response Time:	90% of final reading in 10 sec. — from nitrogen to air.
Temperature Range:	25-40°C.
Sample Size:	3-8 milliliters.
Oxygen Consumption by Sensor:	Less than 10^{-7} grams $\text{O}_2/\text{hr.}$ (.1 $\mu\text{l}/\text{hr.}$) in air.
Temp. Stability:	0.02°C in sample chamber.
Oxygen Leak Rate Error:	Less than ½% of full scale/15 minutes of operation.
Stirrer Speed:	400 rpm 50 Hz — 480 rpm 60 Hz.
Power Required:	0.12 amps, 117V, 50-60 Hz.
Recorder Required:	100 MV f.s. — 400 ohm input impedance min. Chart Speed — 8 to 15 inches/hr. for 5" chart, or multiple speed.

ASSEMBLING THE APPARATUS

The Model 53 Biological Oxygen Monitor System includes the following components:

- 1 Model 53 Electronic Unit
- 2 Model 5331 Oxygen Probes
- 1 Model 5301 Standard Bath Assembly
- 1 Model 5775 Probe Service Kit
- 1 Model 5350 Membrane Applicator Kit

The Model 5301 Standard Bath Assembly has four sample chambers kept at constant temperature by a surrounding water bath and provided with a built-in magnetic stirrer. The Constant Temperature Circulator is connected to the water bath.

The Model 5331 Oxygen Probes are held in lucite plungers which fit closely into the sample chambers.

The oxygen probes connect to the Model 53 which supplies a polarizing voltage and provides meter readout and recorder signal.

Assemble the 5301 Standard Bath and apparatus in the following manner:

1. Insert four glass sample chambers into the holes in the top of the Model 5301 Bath.
2. Wet 8 of the larger rubber "O" rings with distilled water
3. Place two "O" rings over each of the sample chambers.
4. Place nylon hold-down rings over the "O" rings then push down and twist clockwise to secure them under the stainless steel studs.
5. Plug line cord of Model 5301 Standard Bath into the convenience outlet on the rear of the Model 53.
6. Connect bath unit to Constant Temperature Circulator with tygon tubing. (Inlet and outlet for the circulating water should be chosen so that air is eliminated from the chamber.)
7. Fill circulator with distilled water and set to desired temperature.
8. Connect recorder terminals on rear of Model 53 to recorder. **NOTE:** The red terminal on the Model 53 is positive and is at earth ground. The recorder should therefore be operated with its terminals ungrounded or with the positive terminal grounded.
9. Prepare oxygen probe for operation (see section on probe preparation).
10. Plug probes into the jacks at rear of Model 53.
11. Place strip of numbered marking tape on each probe for identification.

MAKING A MEASUREMENT

The following description is intended as a general guide for using the Model 53 Biological Oxygen Monitor System.

1. Turn on circulator. Use low heat setting (I). (High heat (II) can be used for rapid warm-up.)
2. With the Model 53 turned off check the mechanical zero of the meter (pointer should indicate zero). Tap meter case to overcome pivot friction — adjust with the screw on the meter case.
3. Turn on Model 53 and release brake on Bath assembly.
4. Turn Model 53 Selector Switch to AMP ZERO.
5. Place 3 ml of air saturated distilled water and a magnetic stirrer in one sample chamber of the 5301 Standard Bath assembly.
6. Allow 3 minutes for temperature equilibrium.
7. Insert PROBE I into the sample tube (brake on). Expel all air through the slot in the plunger (a slight twisting of the plunger helps to gather the bubbles at the slot). Solution level in the plunger slot should be between the lower end of the plunger and the overflow groove.
8. Release stirrer brake.
9. Set meter pointer to zero with AMP ZERO control.
10. Adjust the recorder to zero. (See instructions of particular recorder).
11. Turn the Selector Switch to the AIR position and turn Probe Switch to PROBE I. Set meter to 100% saturation with the PROBE I control.
12. Set the recorder to full scale using the RECORDER ADJUST control at rear of Model 53.
13. Observe system stability as indicated by recorder trace. Trace should be noise free and have a drift of no more than $\frac{1}{2}\%$ in 15 minutes.
14. Probe Test — perform once a day as routine.
 - a. Turn Selector Switch to TEST position A and wait until recorder traces a steady value.
 - b. Set reading to 90% with PROBE I control.
 - c. Switch to B and wait for steady trace.
 - d. Trace B should be no lower than 87% of full scale after $2\frac{1}{2}$ minutes. If the probe does not meet this specification the membrane should be replaced. If the performance still does not improve the probe should be cleaned.
15. Reset meter to 100% after probe test.
16. Place sample with appropriate solution (total volume 3 ml) and magnetic stirrer into a sample chamber.

17. Allow 3 minutes for sample temperature equilibrium.
18. Insert PROBE I into sample chamber as in Step 7.
19. Allow 5-15 minutes for the recorder to produce a trace defining the oxygen uptake rate.
20. Determine the actual oxygen consumption rate as in the following example:
Assume a change from 82 — 64 percent of saturation in 5 minutes — this means that $82-64=18\%$ of the solution was consumed in 5 minutes.
Assume the solution was 3 ml of Ringers solution at 37°C . If Ringers solution saturated with air at 37°C and ambient barometric pressure contains $5.0 \mu\text{l O}_2/\text{ml}$ of solution — then a 3 ml sample contained $5.0 \times 3 = 15 \mu\text{l O}_2$ when saturated.
A change of 18% in saturation means $15 \times 18\% = 2.7 \mu\text{l O}_2$ was consumed in 5 minutes. Or on an hour basis $2.7 \times \frac{60}{5} = 32.4 \mu\text{l}$.

DISCUSSION

1. Polarographic Oxygen Sensor

The Clark type oxygen sensor is a complete polarographic system in itself. A thin membrane stretched over the end of the sensor isolates the sensor elements from their environment. The membrane is permeable to gases and allows them to enter the interior of the sensor. When a suitable polarizing voltage is applied across the cell, oxygen will react at the cathode causing a current to flow through the cell. The amount of current which flows is proportional to the amount of oxygen to which the membrane is exposed. The sensor actually measures the oxygen pressure. Since oxygen is rapidly consumed at the cathode, it can be assumed that the oxygen pressure inside the membrane is zero. Hence, it can be seen that the force causing oxygen to diffuse through the membrane is proportional to the absolute pressure of oxygen outside the membrane. If the oxygen pressure increases, more oxygen diffuses through the membrane and more current flows through the cell. A lower pressure results in less current. The membrane diffusion is directly proportional to pressure and the oxygen-cell current relationship is stoichiometric, thus a linear relationship exists between external oxygen pressure and cell current.

The YSI Model 5331 Oxygen Probe consists of a .025" diameter platinum cathode and a silver anode cased in an epoxy block. The configuration of the end facilitates cleaning, minimizes the volume of filling solution and insures membrane tension. A teflon membrane is secured with an "O" ring.

The polarographic sensor has some characteristics that should be understood by the serious worker.

Electrical Characteristics

The current output of the sensor is dependent upon the cathode area and the permeability of the membrane directly above the cathode. Individual sensor variations can be attributed to differences in membrane characteristics — both film irregularities and variations of installation methods contribute to the changes. While using membranes from the same package variations of $\pm 10\%$ may be experienced. Wider variations should be suspect — look for gross membrane imperfections, membrane rupture or damage during installation.

Voltage Plateau

The current output — applied voltage relationship is an important characteristic in evaluating the performance of the sensor. A long flat plateau region gives independence of applied voltage and results in linearity of output signal for a wide range of oxygen pressures.

The sensors are operated with a polarizing voltage of 0.8 volt. The plateau specification is that the output signal shall change less than 3% when the polarizing voltage is lowered to 0.7 volts. Referred to system performance, at worst case this translates to a departure from linearity of less than 0.2%. Thus the error is not significant and is not a function of the sample system nor the type of gas used (air or oxygen).

The probe test functions of the Model 53 electronics provide means for a plateau check.

The important operating characteristics of the probe are:

1. Plateau slope
2. Speed of response to a stepwise change in polarizing voltage
3. Noise
4. Stability or drift rate

The plateau test should show a change of less than 3% (for test voltages 0.8 and 0.7 — A & B positions on switch) for new and freshly cleaned probes. Probes showing slopes of 5 to 8% (older probes or those needing cleaning) may prove entirely serviceable.

Check the probe recover time when subjected to a step change in polarizing voltage — make the observation when changing from the "A" to the "B" position. The signal should be within 3% of the "A" value $2\frac{1}{2}$ minutes after switching.

Noise can be attributed to many parts of the system — to poor grounding, pick-up from high voltage machines, etc., but two kinds of noise can originate in the probe.

- a. The occasional burst of spike occurring frequently but randomly. Check the second probe — if both probes behave in the same manner the trouble is probably elsewhere.

If the noise originates in the probe — a damaged membrane may

be the cause — folds or creases in the membrane are always suspect. Examination of the probe under a low power microscope can be useful. Check for holes, creases, KCl growths, or drying out under membrane.

- b. Continual noise of several percent of full scale which may increase in magnitude with time. The membrane may be in perfect condition. The silver anode may not be making good reference contact with the solution. Cleaning with ammonia is recommended.

Temperature

The signal from the sensor is dependent on the temperature, and in particular, the temperature of the membrane adjacent to the cathode. The permeability of the membrane material is temperature sensitive. Most materials have a temperature coefficient of permeability of 3 to 5 percent per degree Centigrade. Thus good temperature control is required and temperature equilibration time must be considered when making changes in the set up.

Oxygen Consumption by the Sensor

The polarographic sensor consumes oxygen.

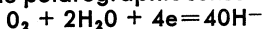

The rate of oxygen consumption by the sensor is in direct proportion to the current produced by the sensor. The most practical way to minimize the errors introduced in this manner is to use a small area cathode.

A sensor current of 1 microamp is equivalent to 8×10^{-11} grams of oxygen per second consumed by the sensor.

The Model 5331 probe has a sensor current of about $\frac{1}{3}$ microamp in air at 37°C. For a biological system containing 25 micrograms of oxygen (3 milliliters at 37°C) about .10% error would accrue per 15 minutes of operation. For most work the error can be neglected, but when using very small samples or conducting experiments for extended periods significant errors may be manifest.

Electrolyte Saturation and Bubbles in Electrolyte

The oxygen sensor must be considered a part of the total system under study.

For example, the KCl electrolyte which fills the sensor has a definite volume and contains dissolved gases including oxygen (only the electrolyte covering the platinum electrode is free of oxygen). The amount of oxygen "stored" in the electrolyte depends on the volume of the electrolyte and its immediate history.

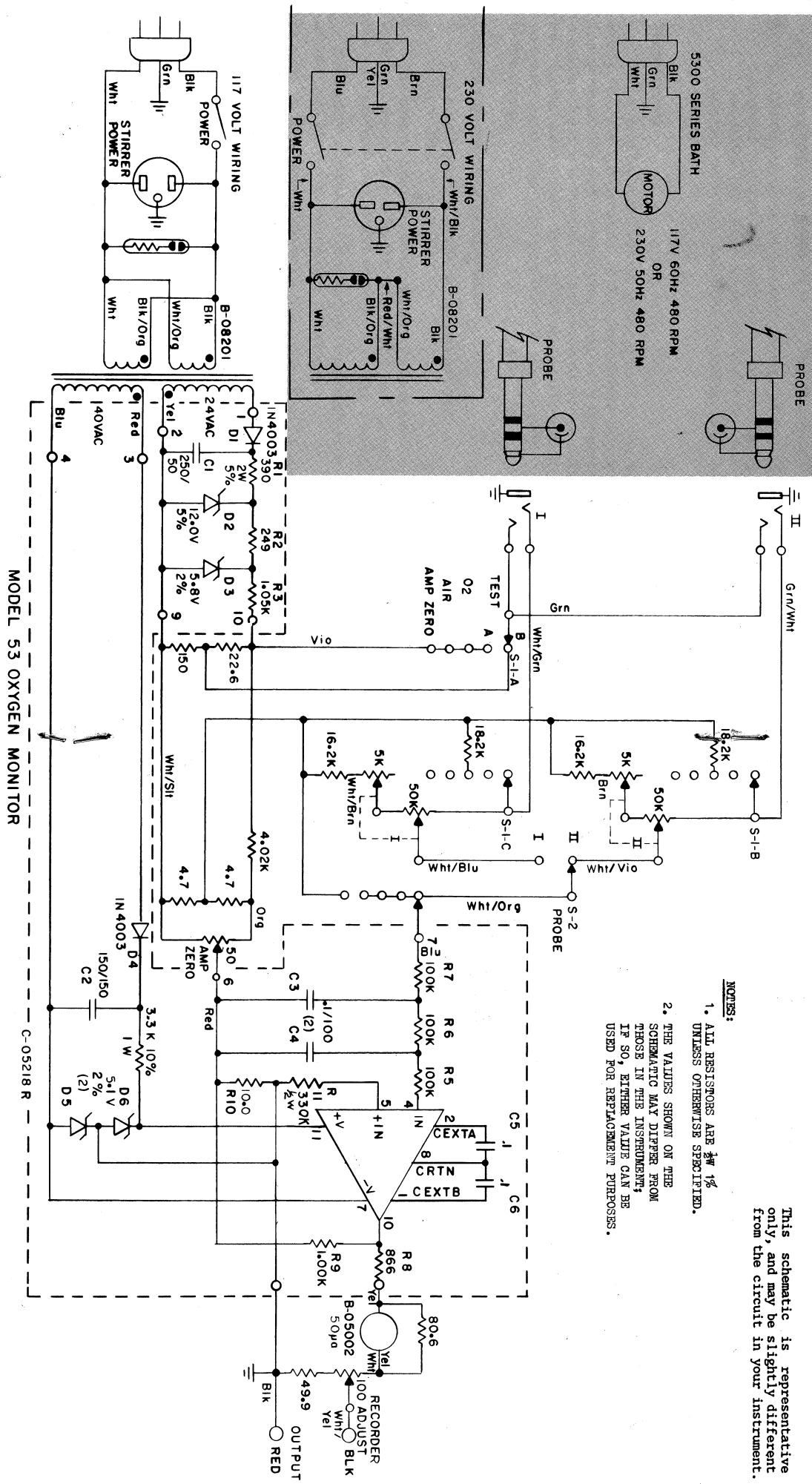

- NOTES:**
1. ALL RESISTORS ARE $\pm 1\%$ UNLESS OTHERWISE SPECIFIED.
 2. THE VALUES SHOWN ON THE SCHEMATIC MAY DIFFER FROM THOSE IN THE INSTRUMENT; IF SO, EITHER VALUE CAN BE USED FOR REPLACEMENT PURPOSES.

This schematic is representative only, and may be slightly different from the circuit in your instrument.

When the oxygen level of the sample is decreased during a run oxygen is induced to leave the electrolyte, pass through the membrane and enter the sample thus introducing an error of possible significance.

The YSI Model 5331 probe has an electrolyte volume of 2 to 3 microliters so that errors from this source may be disregarded except for very small samples.

More serious is the presence of gas bubbles inside the membrane. Volume for volume an air bubble contains 20 times more oxygen than air saturated water. Thus if a large gas bubble is present significant error can occur with normal sized samples. Further, since the equilibrium must be attained by diffusion through the membrane the system may be sluggish and exhibit slow drifts.

Drift of Calibration

A probe in good condition operating in a well controlled environment will exhibit drifts of less than 2%/hour. ½% drift rates per hour are not uncommon but external factors influence the test and some of the external factors are difficult to identify or control.

Changes in the air composition in the laboratory — barometric pressure changes — sudden changes in humidity — a solution left in a sample chamber breeds mold or bacteria — the probe picks up some organic material from hands or from contact with bench.

Care of the Oxygen Probe

The polarographic oxygen sensor is a versatile device capable of high sensitivity and excellent stability if given proper care. Cleanliness is extremely important and proper membrane installation a necessity.

A 10X jeweler loupe or a low power microscope is an invaluable aid in ascertaining the condition of the membrane, both as an aid to maintenance and a help in troubleshooting. Minute details are important to performance — you must be able to observe them.

II. 5301 STANDARD BATH ASSEMBLY

The Model 5301 Standard Bath provides relatively airtight sample chambers which are stirred magnetically and temperature controlled.

The four sample chambers are held in place with locking nylon hold-down rings and sealed with two rubber "O" rings.

The nylon ring also serves as a tensioning device to hold the plunger in position while allowing a very fine adjustment regardless of sample size.

The lucite plunger is provided with a slanting front end and access slot along the side for removal of gas bubbles from the sample. The re-

removal of bubbles is of the greatest importance because of the 20 to 1 increase in the amount of oxygen per unit volume in the gas phase over that in the saturated solution.

The solution level in the access slot should be between the overflow groove and the lower end of the plunger. The small amount of unstirred solution in the slot and around the plunger then serves as a barrier to oxygen diffusion into or out of the stirred solution in the chamber. The error caused by diffusion through this path is no more than ½% per 15 minutes for chamber oxygen pressures operating between 50 and 100% of the outside oxygen pressure.

Errors due to oxygen leakage can be minimized by operating with the smallest possible oxygen pressure differential between the sample chamber and the outside atmosphere, and by limiting the running time of the sample.

If saturating gases other than air are being used, leakage errors may be minimized by flushing the overflow groove with the saturating gas.

The access slot can also be used for the introduction of samples, inhibitors and activators into the sample chamber with the aid of a hypodermic syringe.

Stirring is necessary to prevent oxygen depletion by the probe of the solution directly adjacent to the cathode. The stirring constantly renews the solution in front of the cathode and results in steady reading.

In situations where more or less sample agitation is desired other stirrers can be substituted. If other stirrers are used, the probe operation should be checked with stirrers interchanged to see that readings are not changed.

III. CALIBRATION

The polarographic oxygen sensor measures oxygen pressure and means must be employed to relate the indicated oxygen pressure to the actual amount of oxygen present.

The amount of oxygen that can be dissolved in a solution depends upon the temperature of the solution, and also the composition of the solution. Both high temperatures and high concentration of dissolved salts decreases the amount of oxygen the solution can hold.

To achieve effective calibration two requirements must be met:

1. The solubility of oxygen must be known for the particular solution being used.
2. An experimental method of certain reproducibility must be used to achieve day to day calibration.

The solubility of oxygen in many solutions can be determined from the literature. The "Bunsen Coefficient" is usually expressed as ml O₂/ml fluid. The solubility of oxygen in other solutions may be determined experimentally. In many cases an exact value for the oxygen solubility is not required but a highly reproducible calibration method is important.

The Model 53 calibration is made against a saturated solution. A sample of the solution to be used is brought to a known temperature and saturated with the gas in question — air, oxygen, or other gas of known composition. The probe is introduced and calibration adjustment is made — set meter to read 100%. The unit is now calibrated for use with a particular solution at a particular temperature and pressure. Meter readings indicate the amount of oxygen present in each milliliter of solution. For example:

Ringers solution was used at 37°C. Assume Ringers solution at this temperature and pressure contains 5.0 microliters O₂ per milliliter of solution when saturated with air. Thus, if 3 milliliters of Ringers solution is being used and the meter indicates 92%, then the entire sample chamber contains $3 \times 5.0 \times .92 = 13.8$ microliters of O₂.

Thus at any time the oxygen content of the sample chamber can be determined.

To determine rate of oxygen use:

Note the meter reading at the start and finish of a given time interval:

Start	92%
Finish	66%*

Time interval 5 minutes

$92 - 66 = 26\%$ of the oxygen was used up in 5 minutes

For 3 milliliters of Ringers solution at 37°C —

$5.0 \times 3 = 15$ microliters of O₂ when saturated with air.

Hence the sample consumed $15 \times 26\% = 3.9$ microliters of O₂ in 5 minutes.

The above method of calibration makes some assumptions that should be noted. First it is assumed that the oxygen solubility value is the same in the total sample mixture as in Ringers solution. This is, of course, not strictly true but where Ringers solution is the principal component of the final mixture it is very nearly true.

The system is sensitive to barometric pressure changes. Thus the calibration is dependent to some extent on the weather and the altitude of the laboratory. The Weather Bureau indicates that the normal extremes

* At standard conditions this represents an O₂ pressure change from 147 mm. to 105 mm. Hg. If a specific biological system requires higher O₂ pressures pure O₂ or O₂ enriched gases can be used.

of barometric variation is plus or minus 1.01 inches (25 mm.) from a mean value of 29.92 inches (760 mm.) Thus variations of $\pm 3\%$ can be expected on a day-to-day basis. This error is significant on an absolute basis, but where comparative results are sought correction may well be unimportant. More serious is the altitude of the laboratory. The calibration value will vary in direct proportion to the atmosphere pressure:

Altitude	Atmospheric Pressure
Sea Level	750
1000 feet	733
2000 feet	707
3000 feet	681
4000 feet	656
5000 feet	632

For example the "Bunsen Coefficient" is reported at 760 mm. At 5000 feet altitude the saturated solution will contain only $\frac{632}{760} = 83\%$ of the sea level value.

IV. ELECTRONIC UNIT

The Model 53 Electronic Unit provides the polarizing voltage for the 5331 Oxygen Probe and measures the probe current.

The oxygen probe polarizing voltage is 0.8 volts and is derived from a zener diode regulated supply.

The probe current produces a voltage across a suitable resistance (adjustable for calibration) and the resultant voltage is applied to a chopper stabilized amplifier. Meter indication and recorder output signals are provided.

The sensitivity of the current measuring system is reduced by a factor of five for 100% oxygen saturated solutions. This decrease in sensitivity is achieved by changing the resistance in series with the probe and hence reducing the voltage applied to the amplifier.

The probe selector switch on the Model 53 switches the current measuring circuit from one probe to the other while keeping both probes connected to the polarizing voltage. This provision allows the operator to run a control in parallel with his sample.

The voltage applied to the probe can be changed to 0.7 volts (test position B). This allows a check of the polarographic plateau at 0.8 volts (position A) and at 0.7 volts (position B).

DETAILS OF OPERATION

I. Probe Preparation

1. Add distilled water to the KCl crystals and dissolve completely.
2. Transfer a part of the KCl solution to the eyedropper bottle.*

3. Remove the "O" ring and membrane from the probe.
4. Select a membrane from the vial and lay over flared end of membrane holder ring — handle membrane only at ends.
5. Slip large "O" ring down over membrane and membrane holder ring so as to form a drum.
6. Place probe "O" ring over small end of Teflon applicator tool and slide to large end.
7. Seat probe (cable end down) firmly in slot in front end of probe holder. Probe should rest in bottom of round hole.
8. Wet whole tip of probe including "O" ring groove with KCl.
9. Position membrane holder ring (membrane up) directly over probe. Pass ring down over probe until it rests on probe holder. The membrane should now be stretched over the end of the probe and wrinkle free.
10. Keep the membrane tight. Place large end of Teflon "O" ring applicator down against the end of the probe and push-slide the "O" ring down off the Teflon and into the "O" ring groove on the probe.
11. Remove large "O" ring from membrane holder and slip holder off of probe.
12. Inspect the probe carefully. The membrane should be wrinkle free and without holes. No air bubbles should be present under the membrane. Use a loupe or microscope.
13. Cut off the excess membrane material close to the "O" ring with scissors.
14. Rinse away excess KCl solution from outside of probe.
15. Wet "O" ring with distilled water and insert sensor into lucite plunger.
16. Screw nylon probe clamp into plunger with fingers until tight — watch the "O" ring through the lucite — a black ring will appear and widen as screw is tightened. Inspect this black ring for continuity — a true seal is required — watch for a corner of the membrane interfering with the seal.

With a reasonable amount of care in handling a membrane can be expected to last a week or more.

To avoid the need for frequent filling with KCl keep the probe tip in distilled water when not in use. This will prevent water evaporation through the membrane.

* To insure good wetting of the probe tip add 3-4 drops of Kodak "Photo-Flo" solution to each eyedropper bottle full of KCl.

When storing the probe for extended periods clean well and cover with a membrane (no KCl) to protect the platinum and silver elements.

To clean, brighten silver with NH_4OH (reagent diluted 1 to 1) for 10-60 seconds. Brush with a cotton-tipped swab to remove scale — rinse well with DISTILLED water. Clean only when necessary.

II. SAMPLE CHAMBER AND BATH-STIRRER UNIT

Warm Up and Equilibrium Times

When first turned on most circulators are slow to reach the desired temperature. Allow sufficient time for bath assembly to reach temperature before starting measurements.

To minimize the equilibrium time the substrate may be brought to temperature before introducing the sample, and the probe and plunger can be kept at temperature in one of the spare sample chambers. In this manner meaningful data can be gathered within a minute after sample introduction.

Saturation of Solution

As an air saturated solution is heated to the operating temperature of the system, the solution is automatically kept at saturation by the constant evolution of gas. In such a situation it is only necessary to wait 2 or 3 minutes for the temperature equilibrium.

The appearance of gas bubbles after the insertion of the plunger is an indication that the solution has not completely equilibrated.

Saturation of the solution with oxygen mixtures other than air can be achieved by withdrawing the plunger part way up the sample tube. The saturating gas can then be bubbled through the solution and into the space between the plunger and the solution (a 0.05 in. diameter plastic tube will fit down the plunger slot). With the stirrer turned on the solution will saturate in a few minutes. After the solution has been saturated the plastic tubing can be withdrawn back into the overflow groove. Flushing the overflow groove with the saturating gas will prevent the introduction of air into the chamber during the insertion of the plunger into the solution.

To prevent excessive evaporation the saturating gas can be bubbled through water prior to entering the chamber.

Positioning of the Plunger

The plunger should be inserted into the sample chamber so as to expel all gas through the access slot. Bubbles that tend to stick to the plunger surface can be removed by letting enough air (or saturating gas) into the chamber to gather together all bubbles and then reinserting the plunger into the solution to expel the gas.

Solution level in the plunger slot should be between the lower end of the plunger and the overflow groove. It is important that no solution be in the overflow groove during a measurement. Solution in the groove reduces the amount of material being observed in the chamber and increases the liquid surface in contact with the air. A larger liquid surface increases the air diffusion into the solution.

With materials that foam when stirred a slight twisting of the plunger helps to gather small bubbles at the slot.

Small Samples, Inhibitors, and Activators

Additions of a few tenths of a ml can be made to the sample chamber without removing the plunger by using a hypodermic needle inserted down the access groove.

The needle is inserted well into the sample chamber and the introduction is made. After the introduction is completed the solution level in the sample tube is lowered so that it is once again between the overflow groove and the lower end of the plunger.

In making the introduction, the sample solution in the needle and syringe should be free of air bubbles.

A short length of 0.05 in. diameter plastic tubing can serve as a flexible extension to the needle. Teflon tubing is recommended because it is chemically inert and remains stiff at 37°C.

MAINTENANCE

Model 53 Electronic Unit

The Model 53 can be removed from its case by removing the four screws from the underside of the base block, removing the two screws on the ends of the case, and removing a screw at the top of the back of the case. The front panel-chassis assembly can then be removed from the cover.

Model 5301 Standard Bath Assembly

The stirrer motor can be reached by removing the two screws on the bottom side of the base block and loosening the two screws on the perforated metal ends of the motor cover.

The bakelite bath top and glass bath wall can be taken off by removing the four screws on the bath top.

Distilled water should be used in the bath and circulator to prevent the formation of deposits in the system.

NOTE: The circulator should be shut off before sample chambers are removed from the bath units to prevent pumping of water from the bath.

INTERFERING GASES

H₂S, SO₂, halogens, neon nitrous oxide and CO are interfering gases. If you suspect erroneous readings, it may be necessary to determine if these are the cause. These gases have been tested for response.

100% Carbon Monoxide	Less than 1%
100% Carbon Dioxide	around 1%
100% Hydrogen	Less than 1%
100% Chlorine	2/3 O ₂ response
100% Helium	none
100% Nitrous Oxide	1/3 O ₂ response
100% Ethylene	none
100% Nitric Oxide	1/3 O ₂ response

Replacement Parts	5331	5301	5304
Membrane KCL Kit	5775		
30 Standard Membranes (.001 Thk)			
30 ML Bottle KCL W/Kodak Photo Flo			
O-Ring Pak	5945		
O-Ring Applicator	5338		
Chamber Pack		5215	5215
6 Sample Chambers		5213	5213
12 Sealing O-Rings		117-7114	117-7114
Magnetic Stirrer		5222	5309
Stirrer Retriever		5225	5225
Nylon Hold-Down Ring		5092	5092
Plunger		5093	5307

WARRANTY

INSTRUMENT — The Model 53 Electronic Unit and the Model 5301 Standard Bath Assembly are warranted for one year against defects in components and workmanship. Damage through accident, misuse, or tampering will be repaired at a nominal charge when the instrument is returned to the factory or to a YSI authorized dealer.

PROBE—The 5331 Oxygen Probe is similarly warranted.

NOTE: In communications regarding this instrument please mention model number and serial number.

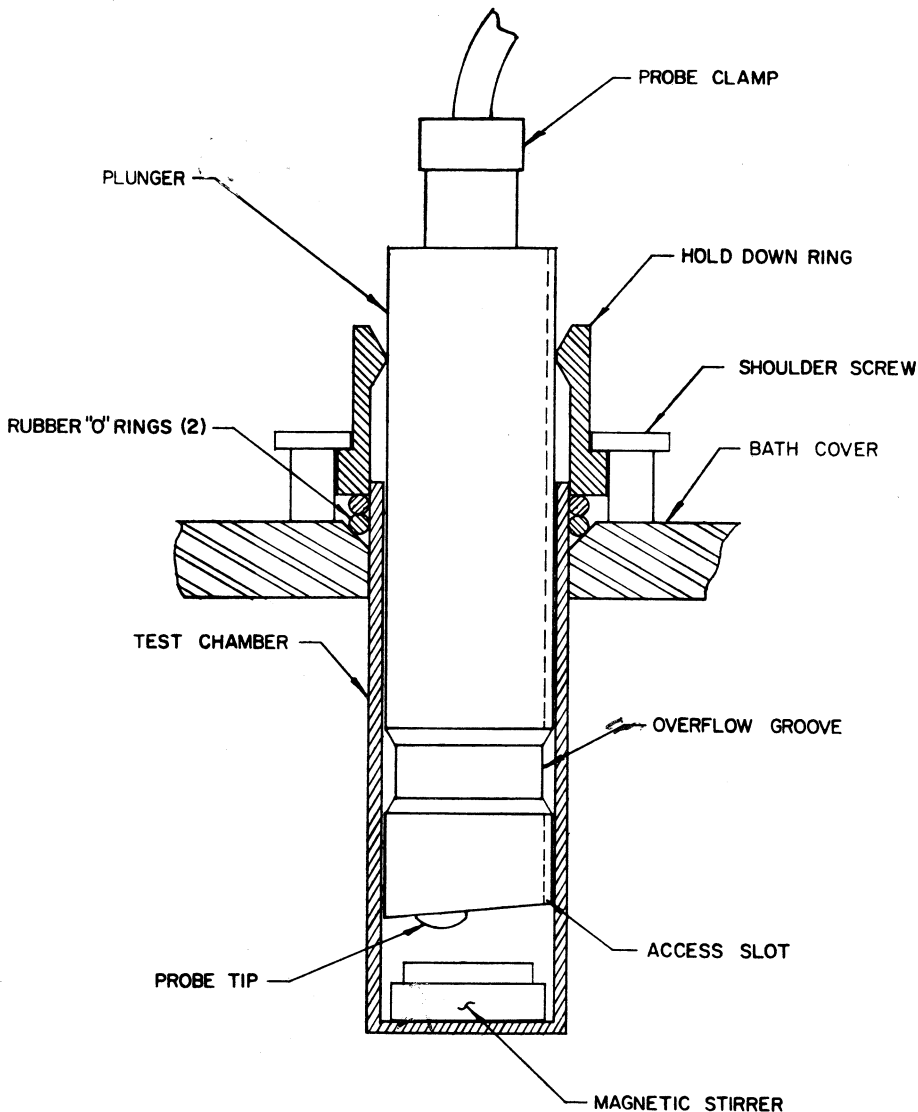

PROBE, PLUNGER AND SAMPLE CHAMBER

